

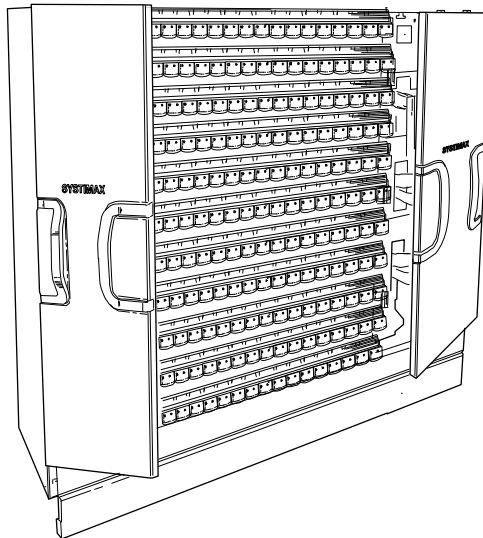


## VisiPatch<sup>®</sup> 360 Wall Mounted Panel System

### General

The **SYSTIMAX<sup>®</sup> VisiPatch<sup>®</sup> 360** wall mounted panel system features IDC cross-connect or patch cord termination and increased density for optimum patch cord management. The wall mounted hardware saves space and easily snaps together without tools. The **SYSTIMAX VisiPatch 360** panel system is an approved component for use in **PowerSUM**, **GigaSPEED<sup>®</sup> XL**, **GigaSPEED Xpress<sup>®</sup>**, and **GigaSPEED<sup>®</sup> X10D** systems.

The VP360-RMBKT rack mounting kit is available that allows the **VisiPatch 360** components to be mounted in a standard 19-inch rack. See instruction sheet 860397058, Rack Mounting Kit for VisiPatch<sup>®</sup> 360 Panel System, for more information.



**VisiPatch<sup>®</sup> 360 Wall Mounted Panel System**

### How to Contact Us

- To find out more about **CommScope<sup>®</sup>** products, visit us on the web at <http://www.commscope.com/>
- For technical assistance:
  - Within the United States, contact your local account representative or technical support at 1-800-344-0223. Outside the United States, contact your local account representative or Authorized Business Partner.
  - Within the United States, report any missing/damaged parts or any other issues to CommScope Customer Claims at 1-866-539-2795. Outside the United States, contact your local account representative or Authorized Business Partner.

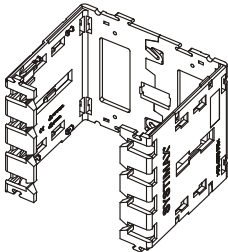
This product is covered by one or more of the following U.S. patents or their foreign equivalents:

6,106,329, 5,915,989, 5,911,594, 6,403,885, 6,379,194, 6,302,699, 6,276,972, 6,118,075, 6,242,698, 5,718,604, 6,302,728, 6,284,980, 6,227,886, 6,159,020, 5,915,992, 7,223,115, 7,322,847.

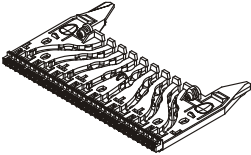
### Tools and Materials Required

- No. 8 drywall or wood screws
- Tape measure
- Bubble level (24" long recommended)
- Drill with extension
- Phillips head screwdriver with long shaft
- 788H1 tool (108062043) with VP360-788-HEAD (760060350) ordered separately
- D914 tool (407484971) with VP360-914-BIT-E (760142463) ordered separately
- Backboard material (highly recommended) – Melamine (18-20mm) thick or sanded plywood 3/4" (19mm) thick.

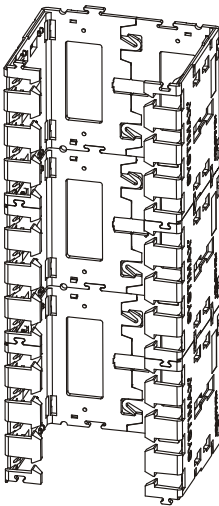
### Parts List



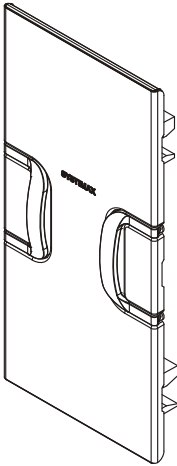
4U Back Panel



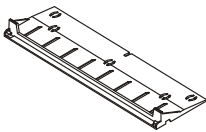
Wiring Block



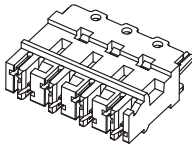
12U Back Panel



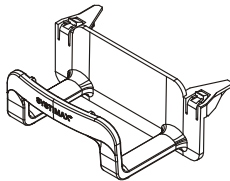
Vertical Trough Cover



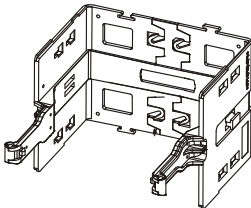
Wiring Block Cover



Connecting Block



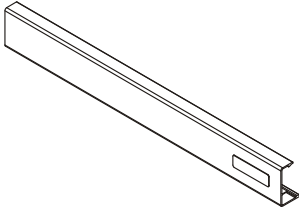
Horizontal Trough



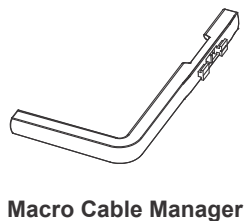
Vertical Trough



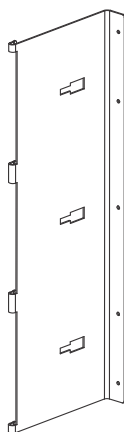
Label Holder



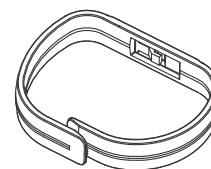
Horizontal Trough Cover



Macro Cable Manager



Side Panel



Micro Cable Manager

Verify parts for the individual kits from the tables below and on the next page.

<b>VP360-4U-32P Panel Kit (760049445)</b>	
Quantity	Description
1	4U back panel
4	Wiring blocks
4	Wiring block covers
32	Connecting blocks
4	Label holders
1	Label sheet
1	Instruction sheet

<b>VP360-12U-96P Panel Kit (760049452)</b>	
Quantity	Description
1	12U back panel
12	Wiring blocks
12	Wiring block covers
96	Connecting blocks
12	Label holders
1	Label sheet
1	Instruction sheet

<b>VP360-12U-10VTCM 12U Vertical Trough Kit (760060285)</b>	
Quantity	Description
3	Vertical troughs
1	Vertical trough cover
3	Macro cable managers
12	#6-19 x .75" self-tapping screws
6	#10-16 x .50" self-tapping screws
1	Instruction sheet

<b>VP360-SIDEPNL Side Panel Kit (760080630)</b>	
Quantity	Description
3	Side panels
1	Instruction sheet

VP360-HCM-KIT-XX Horizontal Cord Manager Kits*				
Quantity				Description
19"	27"	29"	37"	
1	2	1	2	4U back panels
2	4	2	4	Horizontal troughs
2	2	2	2	Horizontal trough covers

\* Horizontal cord manager kits are available in four lengths.  
 VP360-HCM-KIT-19 (760060343) 18.5-inch (470mm) length  
 VP360-HCM-KIT-27 (760060301) 27-inch (686mm) length  
 VP360-HCM-KIT-29 (760060863) 28.5-inch (724mm) length  
 VP360-HCM-KIT-37 (760060871) 37-inch (940mm) length

### VisiPatch 360 Separately Orderable Parts

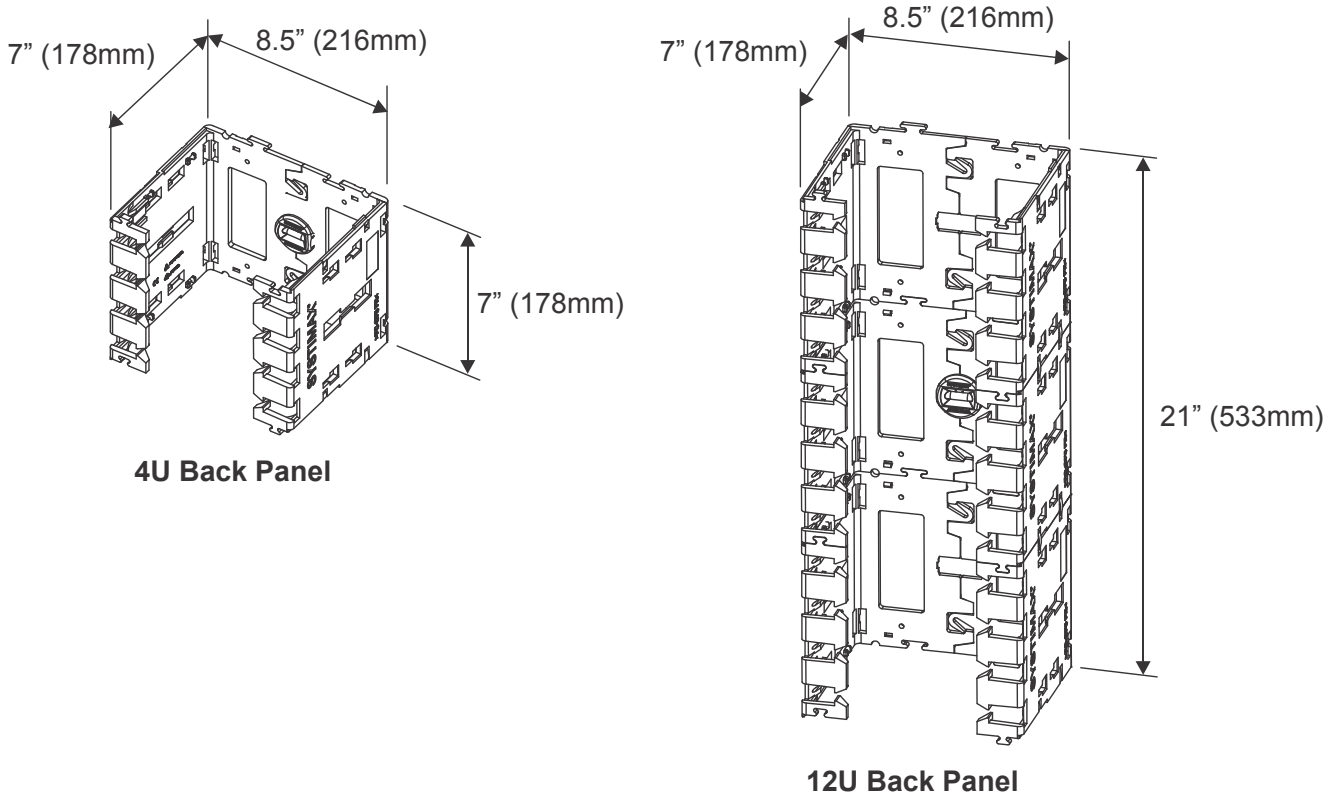
Listed below are **VisiPatch 360** separately orderable parts.

Material ID	Part No.	Description
760068106	VP360-HCM-KIT-19RACK	Horizontal cable management kit for rack mount application
760060251	VP360-4U-BPK	4U back panel kit (includes 2 back panels)
760060277	VP360-CB-10	Connecting block, 10/pk
760060335	VP360-CBF-SK	Cable bundle fastener kit (includes 4 micro cable managers)
760060350	VP360-788-HEAD	4-pair tool head (for use with 788H1 tool)
760142463	VP360-914-BIT-E	1-pair tool bit (for use with D-914 tool)
760161455	VP360-788-BIT-KIT	4-pair tool bit (for use with 788H1 handle)
760162982	VP360-788-BIT-BLADE-KIT	4-pair tool blade replacements (includes 3 blades)
Various (See note)	Various (See note)	GigaSPEED® X10D patch cord
Various (See note)	Various (See note)	GigaSPEED Xpress® patch cord
Various (See note)	Various (See note)	GigaSPEED® XL patch cord
Various (See note)	Various (See note)	1-pair patch cord

**Note:** Contact your local account representative for **Systimax** material IDs and part number information.

## Step 1 – Determine a Mounting Configuration

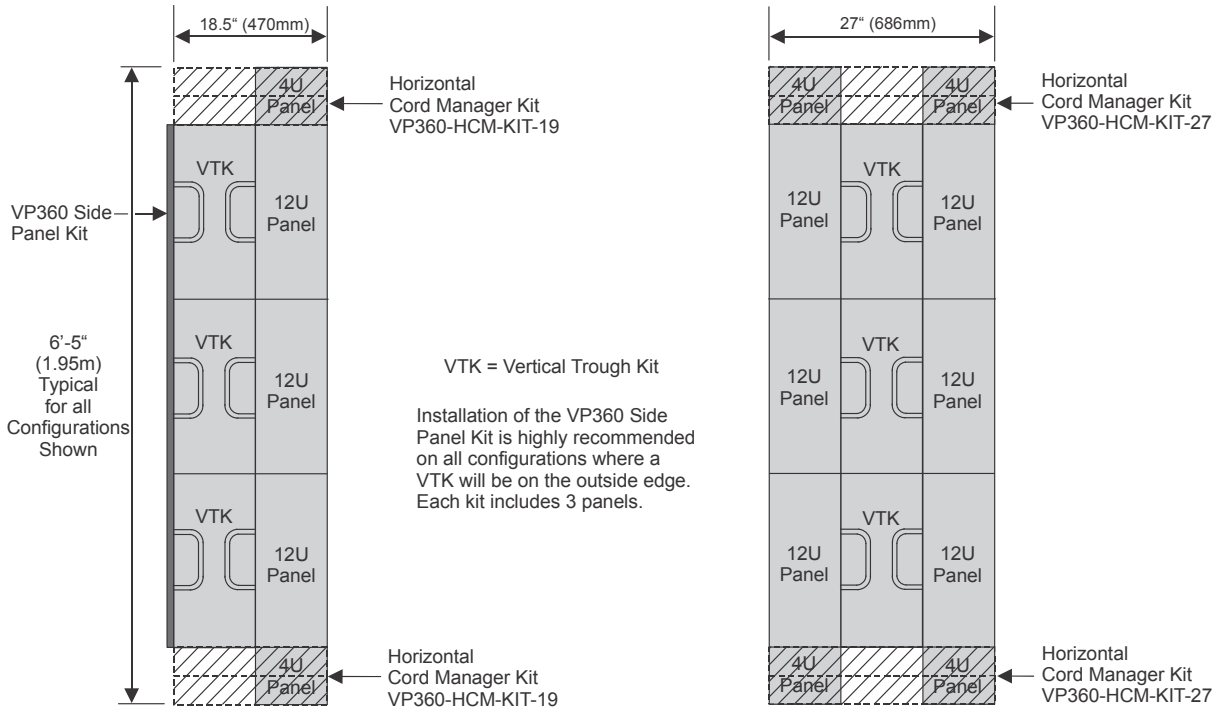
### Back Panel Dimensions



**Note:** A solid mounting surface is required for installation of the **VisiPatch 360** system. **Mounting a backboard on the wall will greatly improve the integrity and quality of the installation.** Recommended backboard materials include 18-20mm thick Melamine and 3/4-inch (19mm) sanded plywood.

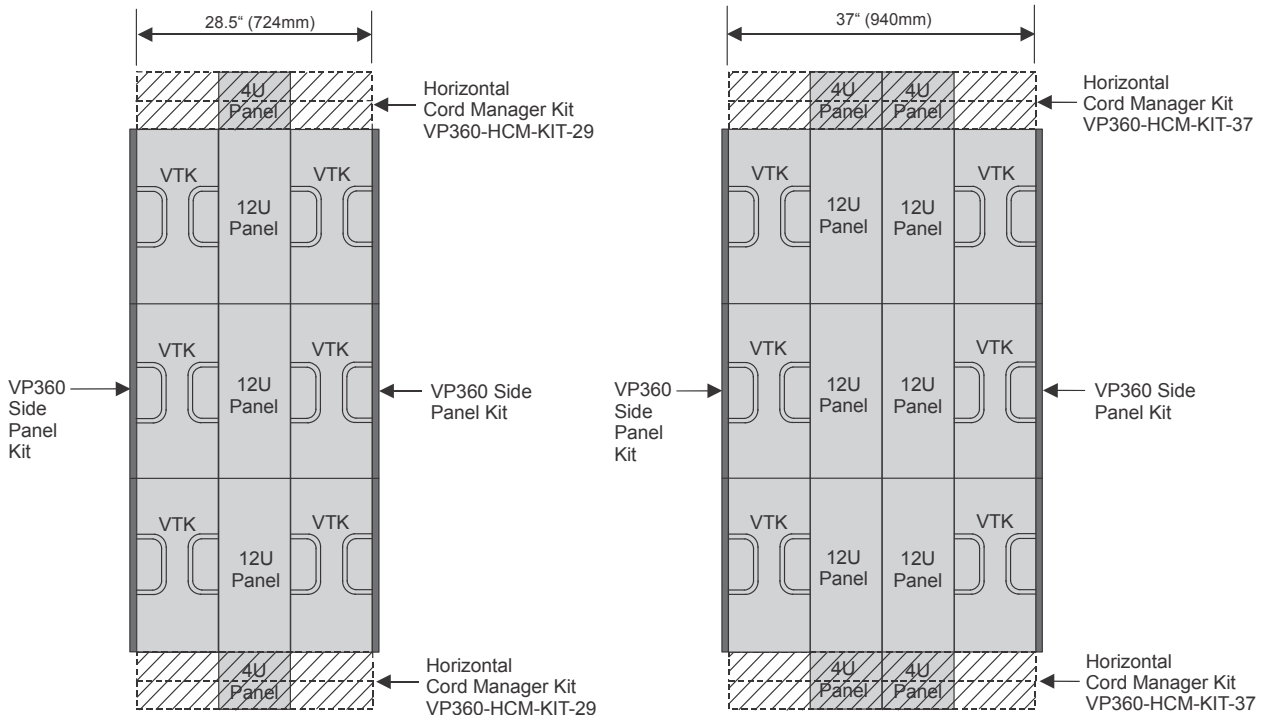
Determine a mounting configuration before beginning installation. Shown on the next page are four recommended configurations for mounting the **VisiPatch 360** components that include the necessary vertical troughs with covers for managing cables. Side panels are also shown, which are highly recommended to be installed on any configuration where vertical trough kit(s) will be on the outside edge of the installation. Three side panels are included in each VP360 Side Panel Kit. Each configuration is a basic template that can be expanded upon as required for this installation and in the future to accommodate growth.

Final installed depth including back panels, wiring blocks, patch cords, and vertical trough covers will be 12 inches (305mm).



19-Inch Wide Nominal Configuration

27-Inch Wide Nominal Configuration  
(Use with XL Cordage Only)

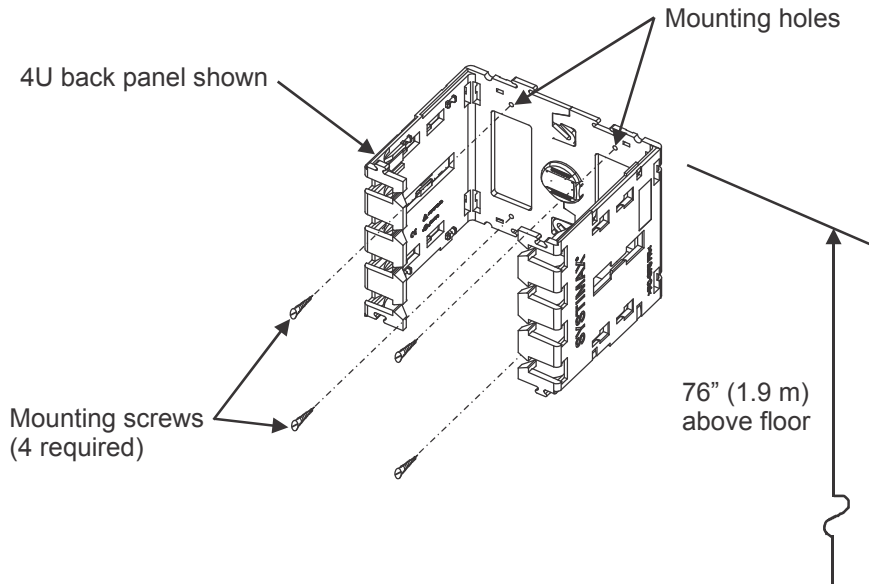


29-Inch Wide Nominal Configuration

37-Inch Wide Nominal Configuration

**Recommended Mounting Configurations, Top View**

**Step 2 – Install Back Panels**

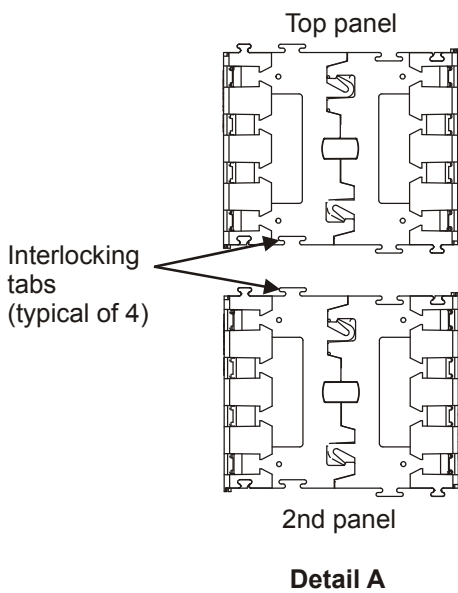
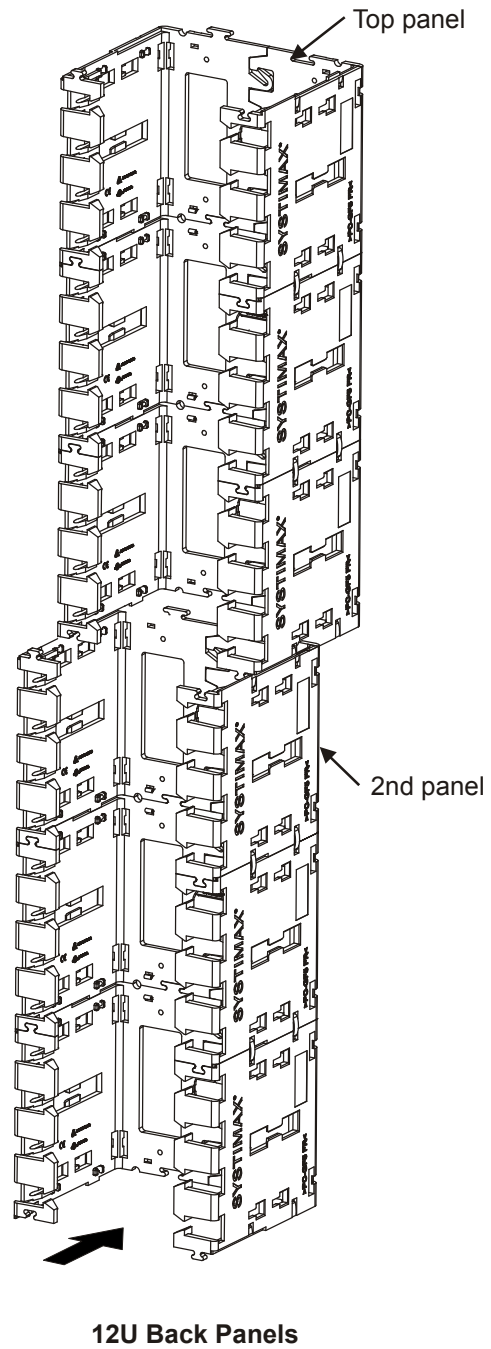
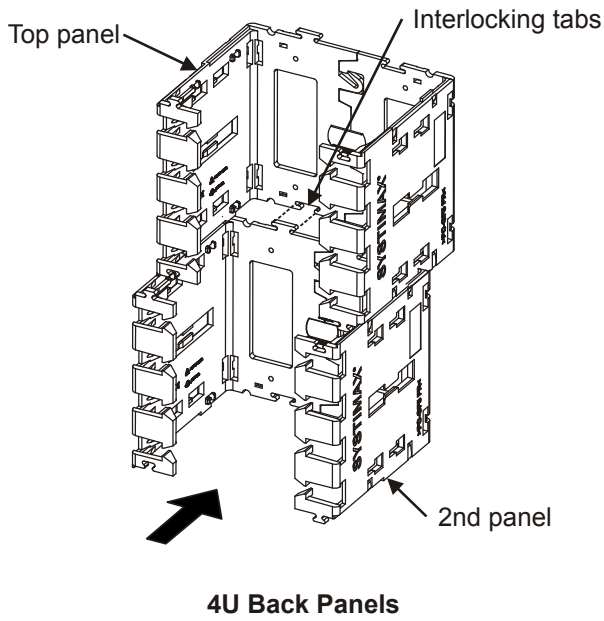


1. Measure 76 inches (1.9m) above floor and mark this position. Using a level, make additional alignment markings at this time to ensure the installation is level.
 

**Note:** It is recommended to install the first back panel (4U or 12U) 76 inches (1.9m) above the floor to allow space for other back panels to be mounted and to allow for future expansion.
2. Locate top of first back panel even with mark and secure it using one No. 8 drywall or wood screw (not provided) in one of four mounting holes provided, using a screwdriver or a drill with extension.
 

**Note:** No. 8 drywall screws work for most interior installations on plywood surfaces. If back panels are being installed on other surfaces, suitable mounting hardware must be obtained locally.
3. With panel supported by one screw, line panel up to previously marked level line. Secure panel in the other mounting hole locations.
 

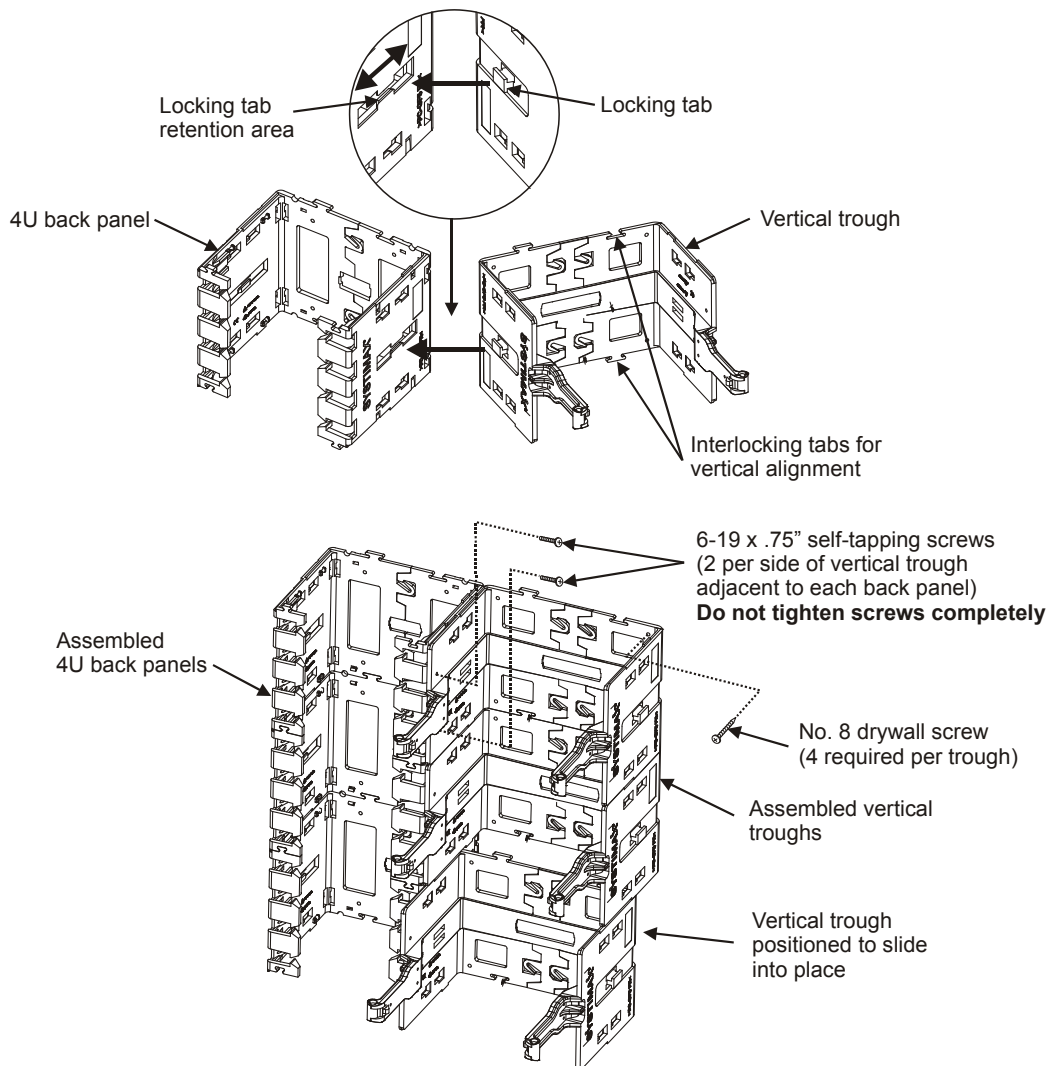
**Note:** Wall fields extending more than three columns may require a commercial level be used to ensure a completely level installation. Also, for large installations it is recommended to attach two 12U back panels together before leveling the first column.



4. Position second back panel tight against bottom of first panel about 1 inch (25mm) away from wall and slide it backwards until the four interlocking tabs on rear of panel are fully seated.
5. Secure second panel using mounting screws in the holes provided.
6. Repeat this procedure for other back panels in this row and for additional rows of back panels.



### Step 3 – Install Vertical Troughs

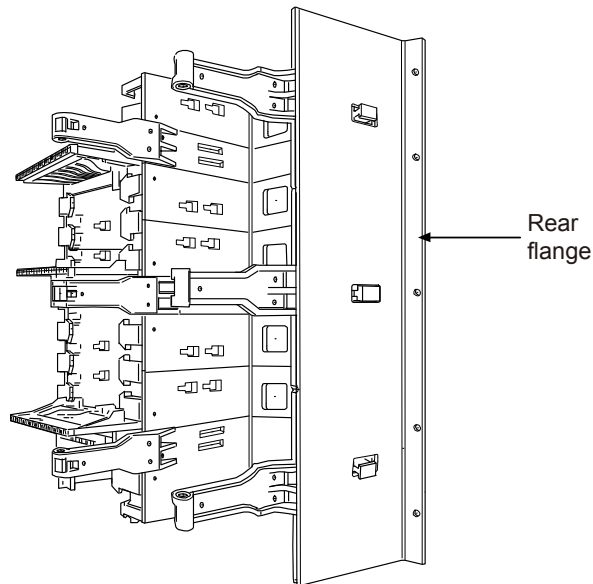


**Note:** Vertical troughs interlock with back panels on right and left sides.

1. Align locking tab on vertical trough with mating slot on back panel and insert.
2. Slide vertical trough or back panel backwards to engage locking tab within retention area.
3. Secure each vertical trough to the adjacent back panel using two provided 6-19 x .75" self-tapping screws on each side as shown above. **Do not tighten screws completely** as this affects how the vertical trough covers fit onto cover mounting arms. Final tightening of screws occurs in **Step 11** during the adjustment procedure for installing vertical trough covers.
4. Also secure each vertical trough to the wall using four No. 8 drywall screws inserted in the holes provided. **Completely tighten these screws.**

**Note:** Alternatively, vertical trough can be installed first and back panels can be snapped in beside verticals.

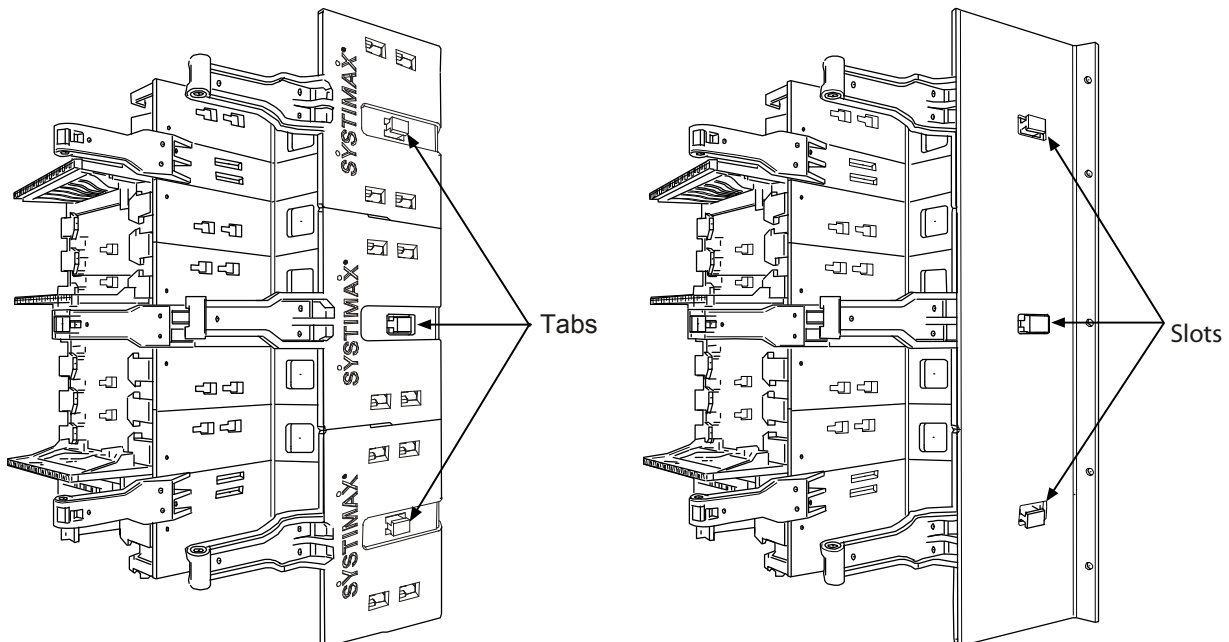
## Step 4 – Install Side Panels



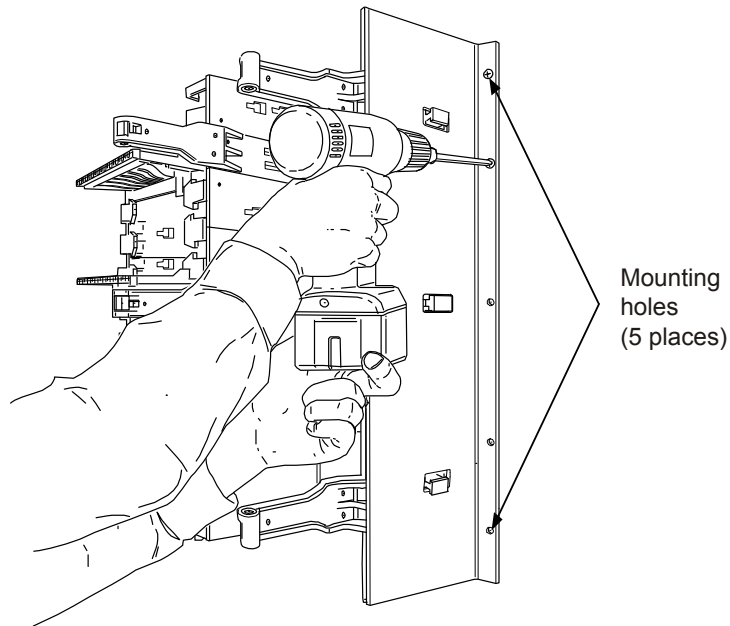
1. Remove one side panel from its packaging. Orient the side panel in relation to the vertical trough and wall surface as shown above for mounting on the right side.

**Note:** Rear flange on side panel must be flat against wall.

The side panel should be rotated 180 degrees when mounting on the left side of a vertical trough.

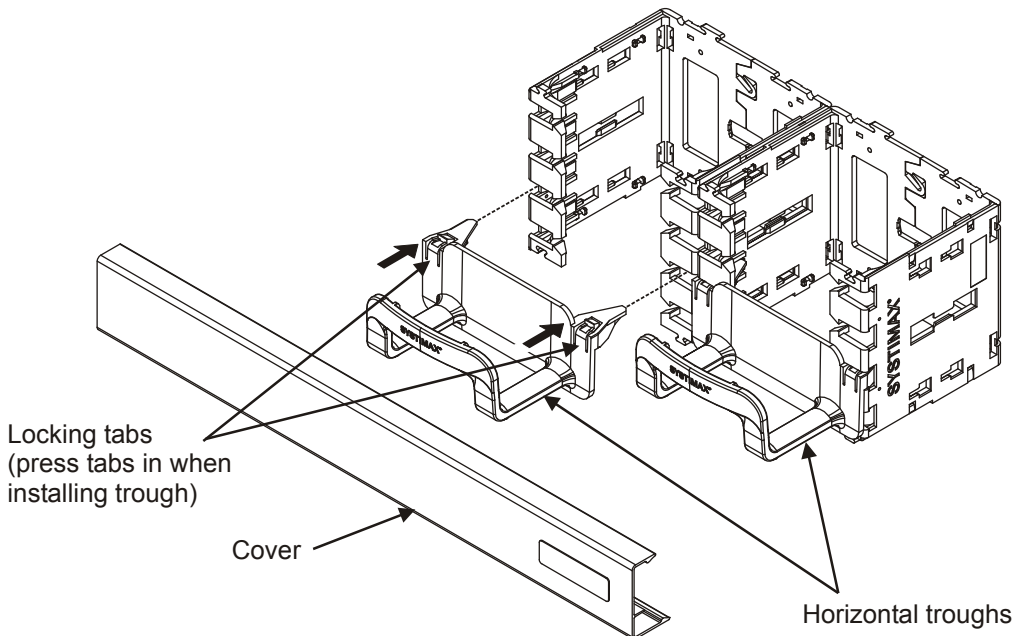


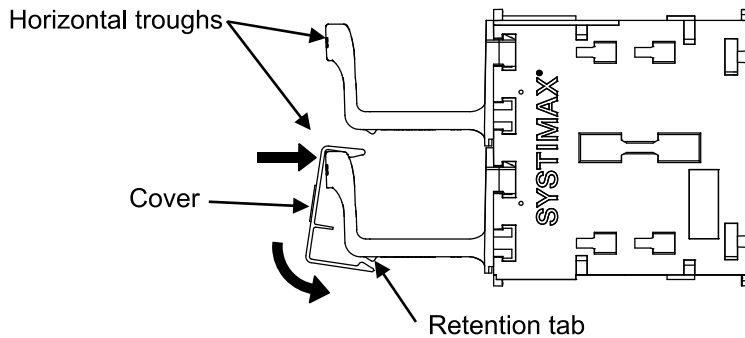
2. Locate tabs on outside of 12U vertical trough section per above figure. Position side panel as shown and hang it on side of vertical troughs so that tabs extend through slots in side panel per above figure.



3. Slide mounted side panel to the rear so that it is snug against wall.
4. Secure the panel to the wall using five No. 8 drywall screws (not included) as shown above.
5. Repeat items 1 thru 4 along the entire vertical length of the unsupported end of a VP360 wall field.

### Step 5 – Install Horizontal Cord Manager Kit





Side View

**Note:** Covers and troughs may be placed during administration.

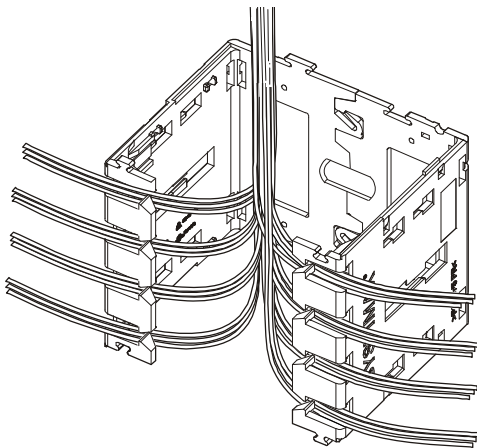
1. The 4U back panels should be installed above and below existing back panels before cable installation. See configurations on page 6.
2. Position horizontal troughs as shown above, press in on locking tabs, and insert ends into slots in back panel until trough is fully engaged.

**Note:** Press in on locking tabs from the front (as indicated) and not down from the top during insertion.

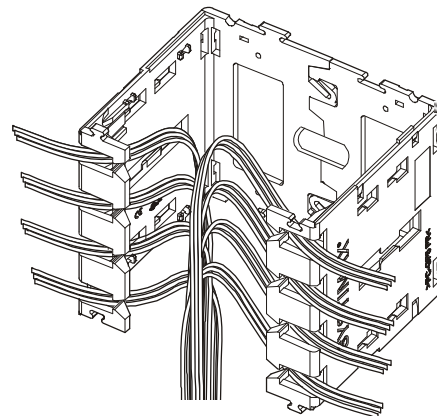
3. Position cover in front of horizontal trough units and set top part of cover in place first, then push in on bottom part of cover until it engages the retention tabs.

**Note:** Remove cover by releasing the bottom part first and then the top.

## Step 6 – Route Cables into Back Panels and Install Wiring Blocks

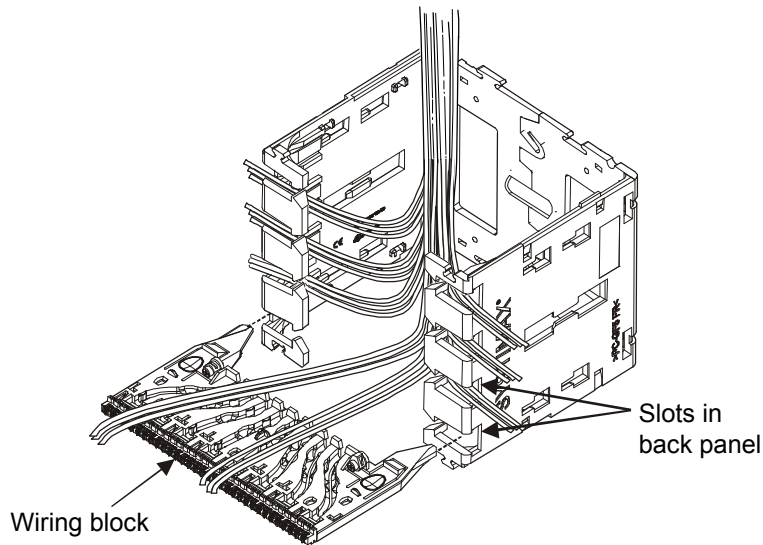


Overhead Cabling



Underneath Cabling

1. Route cables into back panel rows as shown above from overhead or from underneath.

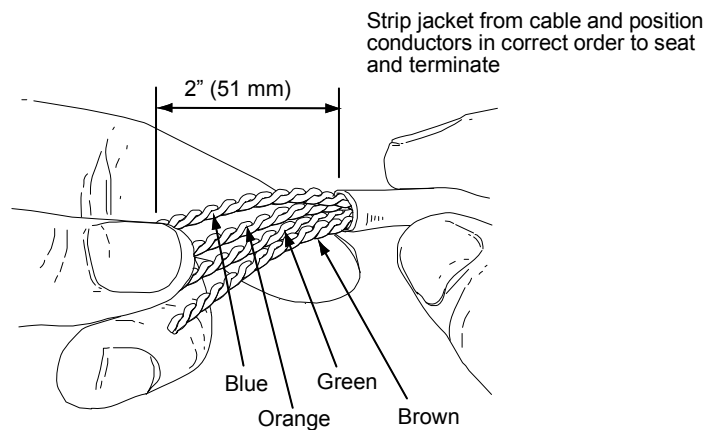


2. Orient wiring block as shown in front of back panel, pull cables out from slots at position where wiring block will go and drape over top of wiring block. Start at the bottom.
3. Insert wiring block into slots of back panel until an audible click is heard.

### Step 7 – Seat and Terminate Conductors

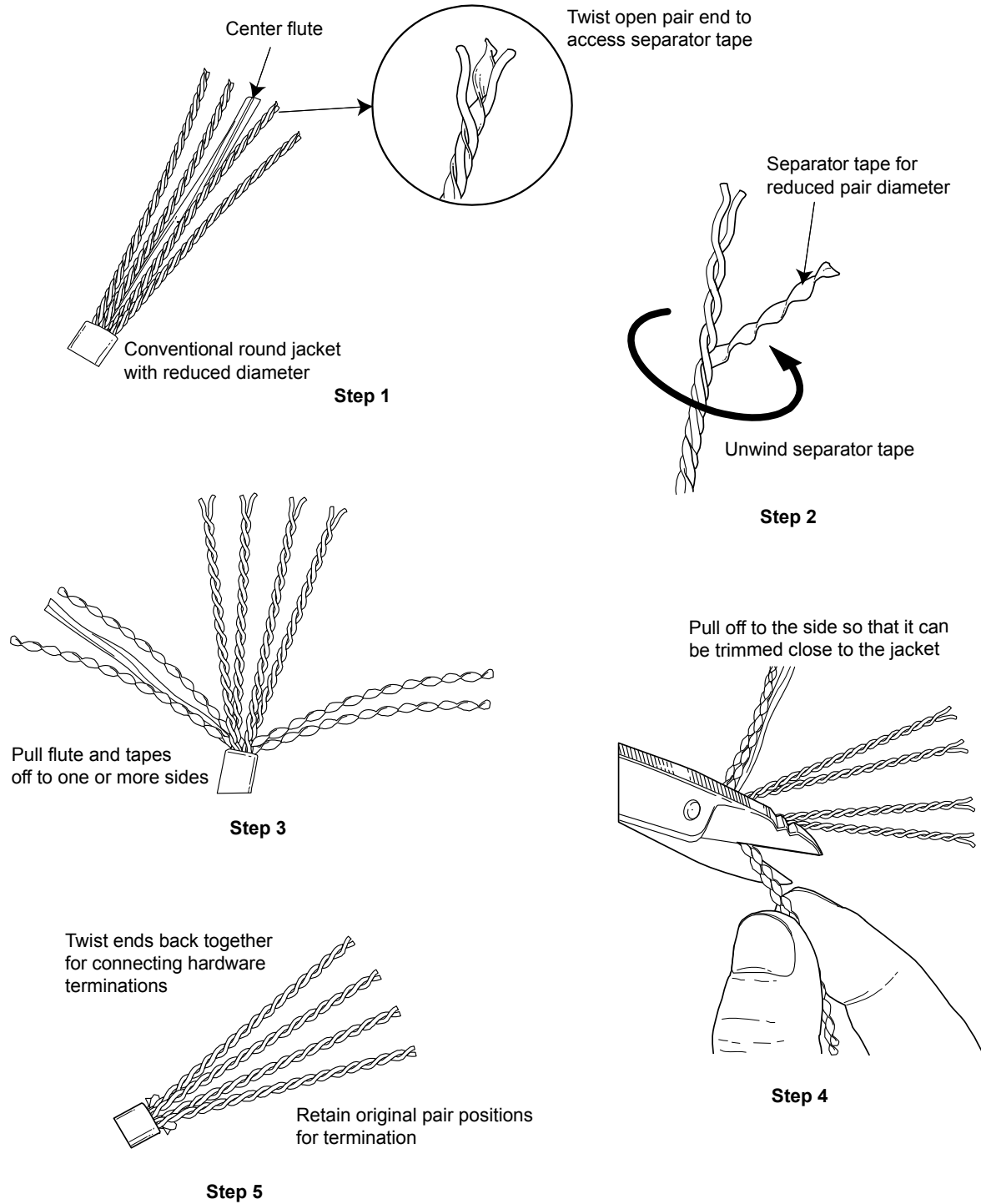


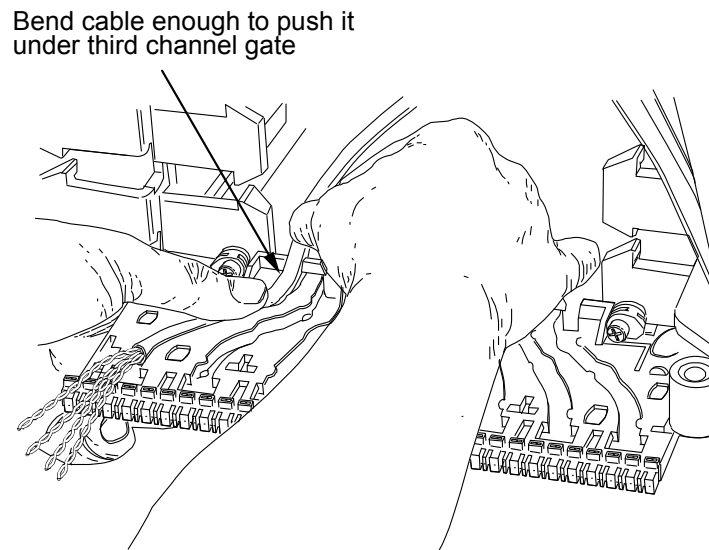
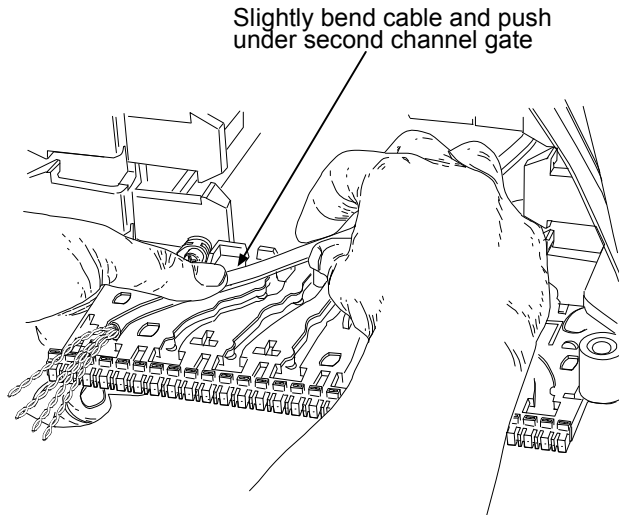
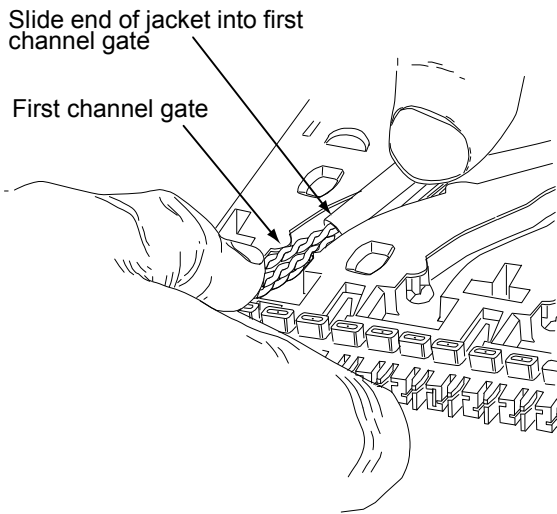
Illustration above shows color codes for wiring block terminations.



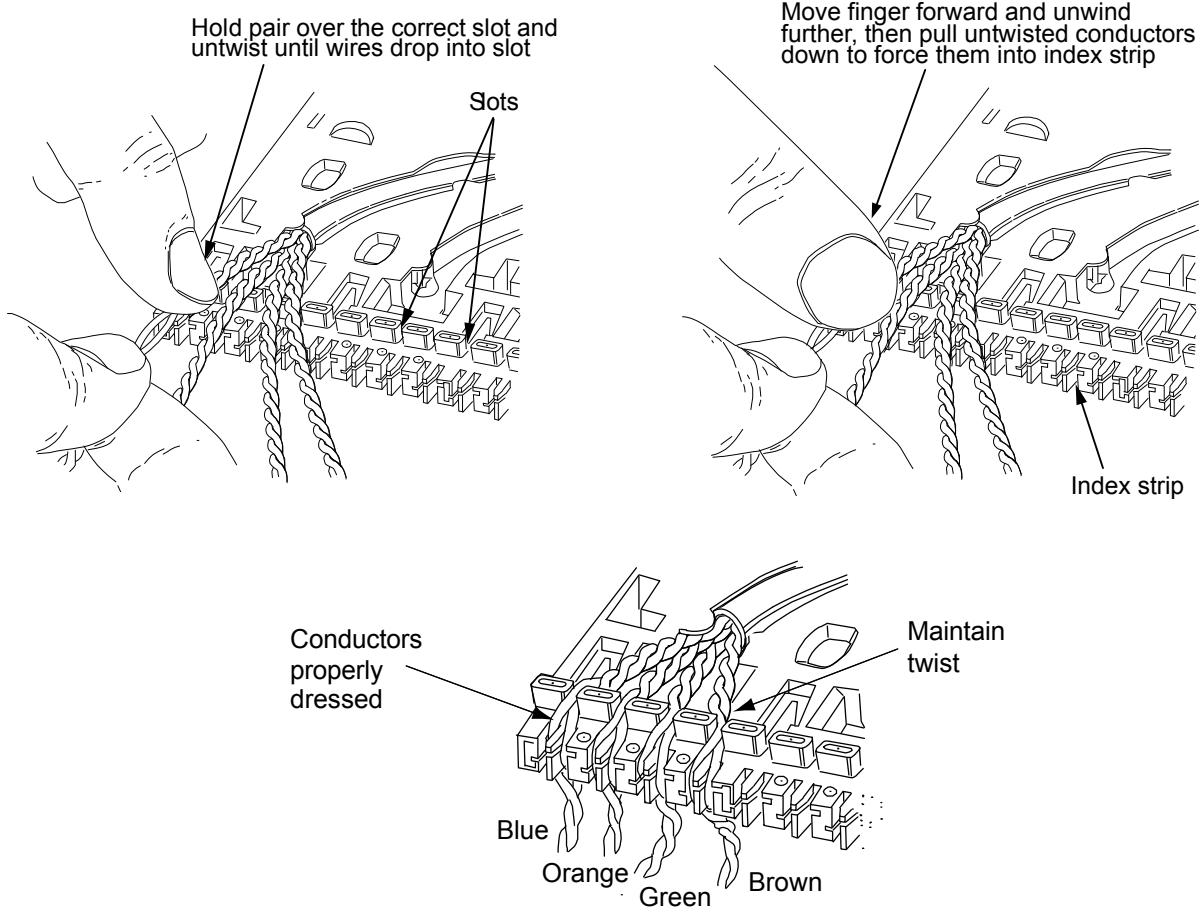
1. Identify location to strip jacket so that cable can be routed along back of back panel to make room for following terminations.
2. Remove at least 2 inches (51mm) of outer sheath from each cable to expose twisted-pair conductors and position conductors in correct order to seat and terminate. Refer to wiring diagram shown above.

**Note:** If using **SYSTIMAX GigaSPEED® X10D 91B series cable, 95B series cordage, or Xpress® 88 series cable**, follow preparation instructions below. Preparation instructions for these cables are also provided in instruction sheet 860469402.

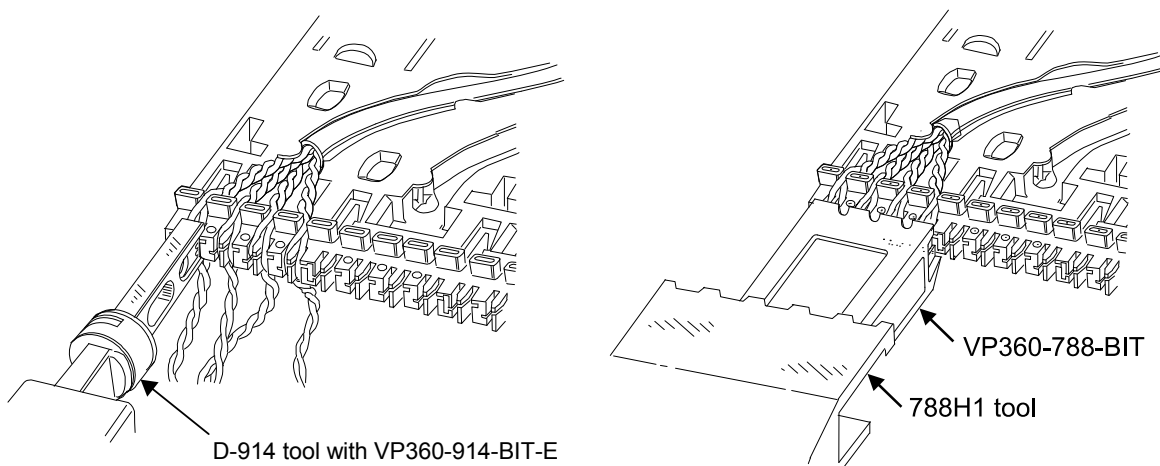




3. Seat each cable into one of the channels provided in wiring block as shown above. Insert cable so that end of jacket is under first gate in channel. Slightly bend cable and push into channel and under second gate. The cable should pop into the channel and catch under the gate. Continue inserting cable until it is seated under all three gates.



4. Dress each twisted-pair into wiring block slots. **Maintain twist in pairs up to slots.**
5. Use index finger to hold conductors down over index strip and use other hand to unwind and insert conductors into appropriate strip. Refer to wiring diagram shown on page 13.
6. Repeat for each cable.





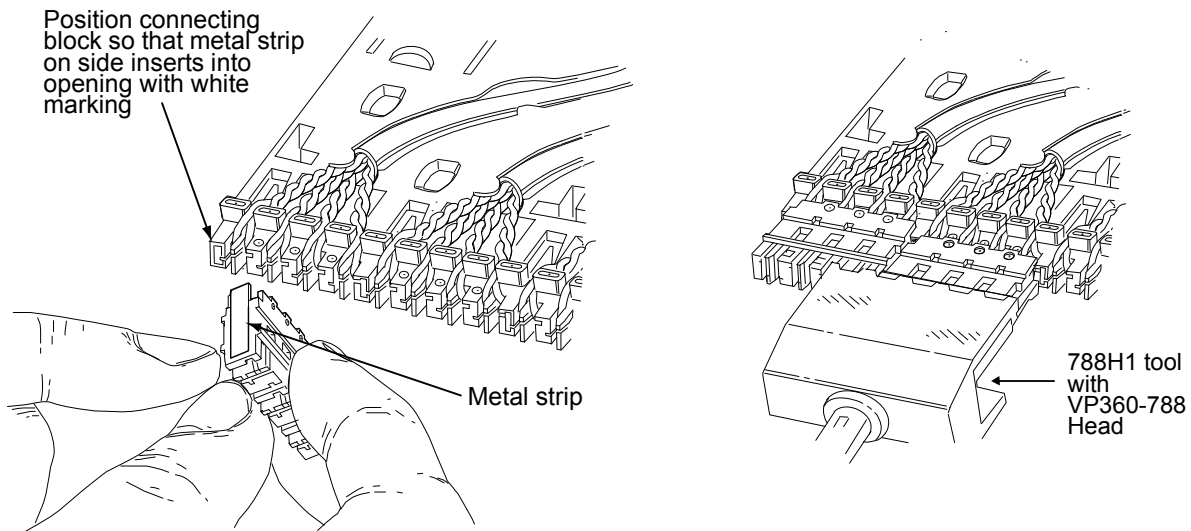
- Using the D914 tool with VP360-914-BIT-E, seat and cut each pair of conductors. Be sure cutting edge is at the bottom.

Or

Using the 788H1 tool with VP360-788-BIT, seat and cut four pairs of conductors at one time. Be sure cutting edge is at the bottom.

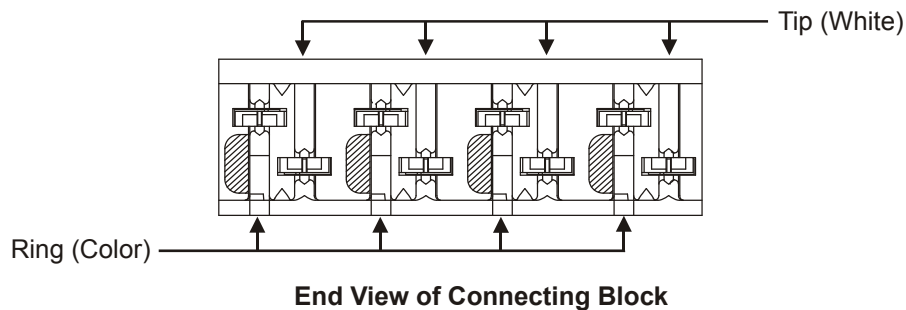
- Repeat for each wiring block.

### Step 8 – Install Connecting Blocks

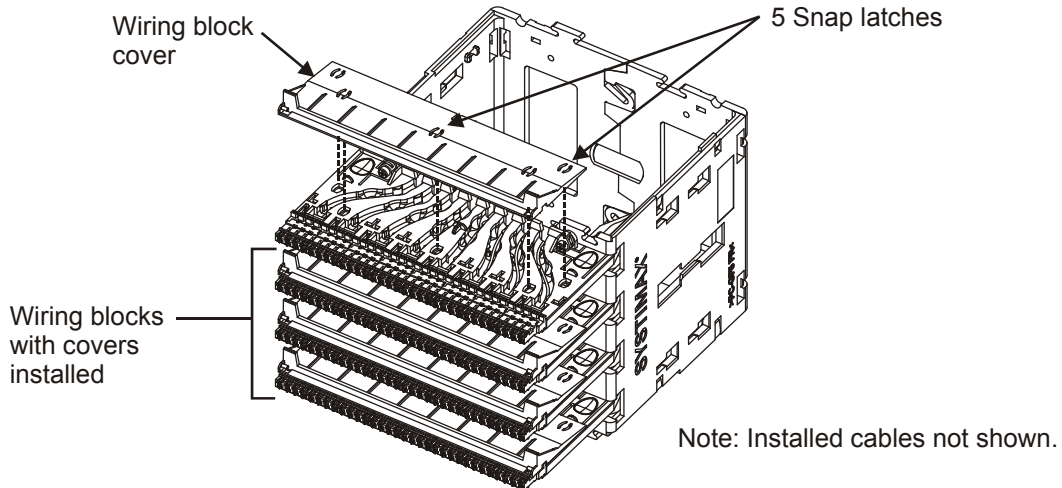


- Orient connecting block so that metal strip on edge of block is facing left and inserts into opening with white marking. Be sure block is properly positioned so contacts cover the wire conductors.
- Using fingers, hold connecting block against front of wiring block.
- Using a 788H1 tool equipped with a VP360-788 head, push in on front of connecting block until impact seated.
- Repeat this procedure until all connecting blocks are seated on wiring block.

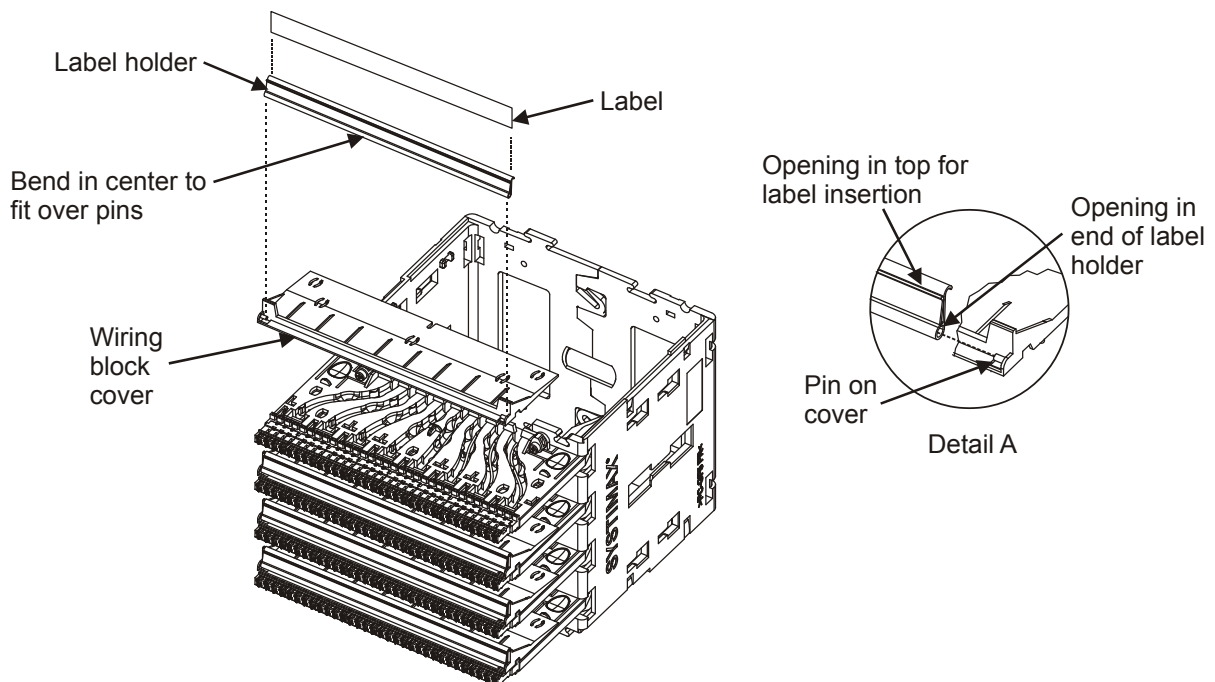
**Note:** The top contacts of connecting block have TIP and RING reversed (see figure below). This is properly accommodated by the **VisiPatch** 360 patch cord plugs.



## Step 9 – Install Wiring Block Cover, Label Holders, and Labels

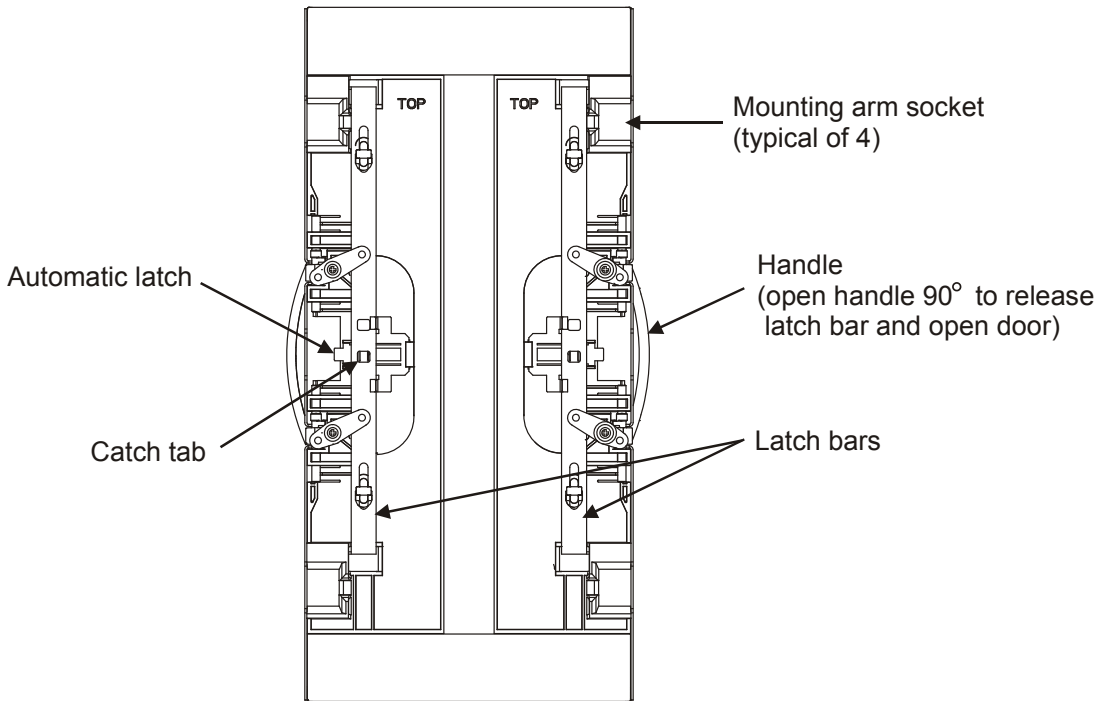


1. Position cover as shown above and push down onto wiring block until latches in cover engage in wiring block.

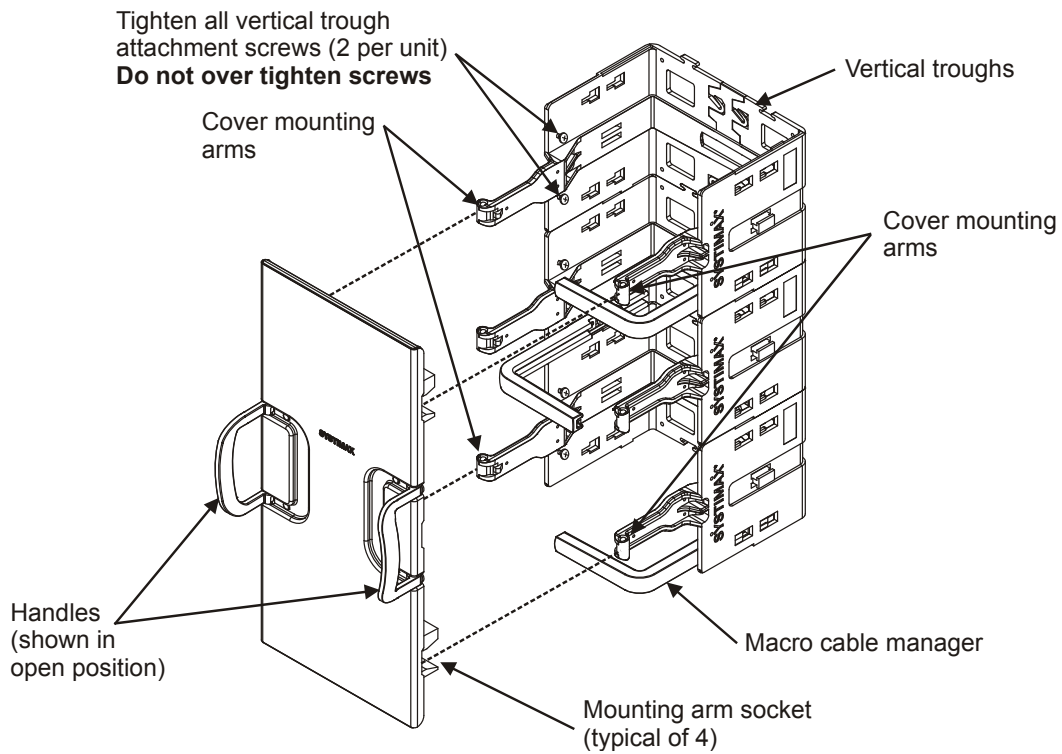


2. Position one end of label holder as shown above and in Detail A, then flex (bend) holder in the middle until the opening in the other end of label holder can be inserted over opposite pin provided in wire block cover.
3. Release label holder.
4. Tear off one label from sheet provided, designate connection as desired, and slide label into opening provided in top of label holder.

### Step 10 – Install Vertical Trough Covers



**Rear View of Vertical Cover**



1. Open both handles on vertical trough cover 90° to set latch bars (see figure on top of previous page). An audible click will be heard when latch bars set. **Both handles must be opened and latch bars set before mounting covers.**

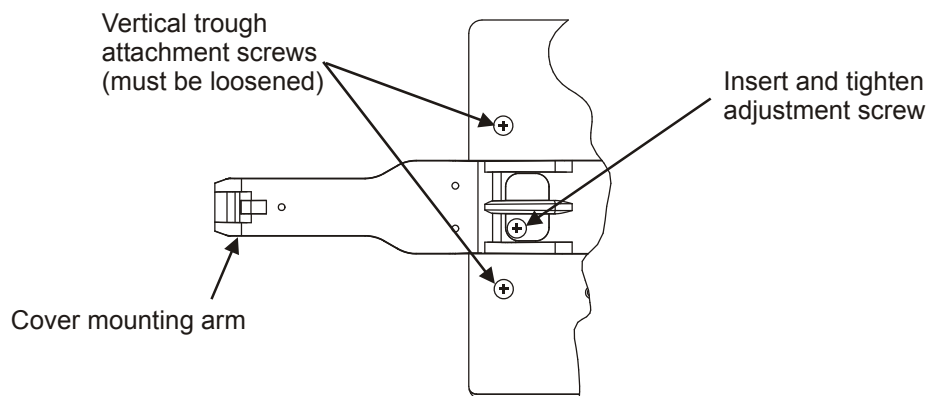
**Note:** Handles do not need to be held open to install cover. They can be in closed position once latch bars have been released.

2. Install cover on vertical troughs by aligning the four mounting arm sockets on the cover with mounting arms on vertical troughs and pushing (see figure on bottom of previous page). Latch bars will automatically engage when cover is installed.

**Note:** Once installed, cover can be opened on either side by opening the handle on that side or removed completely by opening both handles at once and pulling cover off. Always ensure latch bar is released before closing (see item 1).

3. Perform a function check by opening and closing the cover in both directions.
4. If cover aligns properly with vertical troughs, complete installation as directed in item 5. If vertical trough covers do not fit or function properly on cover mounting arms due to conditions such as an uneven wall surface, an arm adjustment procedure should be performed to improve fit. See **Step 11** below.
5. At this time, the screws previously installed in **Step 3** securing each vertical trough to the side of the back panels should be tightened. **Do not over tighten screws** as this can affect how vertical trough covers fit on the mounting arms.

### Step 11 – Cover Mounting Arm Adjustment Procedure



Partial Side View of Vertical Trough

**Note:** Before making adjustments, wiring blocks should be installed in adjacent back panels. The vertical trough arm hinge-holes should be approximately 8.9 inches (227mm) apart, the same width as the door pins for covers to fit properly. Use instructions below to make adjustments.

1. Measure the distance between vertical trough arms to determine which mounting arms require adjustment. Each cover mounting arm can be independently adjusted inward. If spacing exceeds 9 inches (230mm), then adjustment is required.
2. If the two vertical trough attachment screws are not loosened, unscrew them slightly before continuing. **They must be loose for adjustment to be performed.**

3. Insert provided #10-16 x .5 self-tapping adjustment screw into hole as shown above and tighten until the screw contacts adjacent back panel. Continue tightening screw a couple of turns and recheck spacing. Continue until spacing is less than 9 inches (230mm)
4. Install vertical trough cover and verify good fit and function. Repeat if necessary.
5. Repeat items 1 through 4 for adjustment on other mounting arms, if necessary.
6. After adjustments are complete, the vertical trough attachment screws should be tightened until snug with inside of vertical trough. **Do not over tighten.**

**Note:** A vertical trough adjustment fixture is available from your local technical support to aid in measuring vertical arm hinge-hole spacing.